

## Table of Contents

### BENCH SCALES

BenchMark™ SL, CW-80B, SL/HE Series <i>Light-Capacity Bench Scales</i> .....	<b>BS-2</b>
BenchMark™ CW-90B,CW-90XB <i>Light-Capacity Bench Scales</i> .....	<b>BS-4</b>
BenchMark™ Mild, Stainless Steel, HE Series .....	<b>BS-6</b>
BenchMark™ LP <i>Low Profile Bench Scales</i> .....	<b>BS-10</b>
BenchMark™ HD <i>Heavy Duty Bench Scales</i> .....	<b>BS-11</b>
BenchMark™ HDP <i>Portable Heavy Duty Bench Scales</i> .....	<b>BS-12</b>
DIGI® S-YA/S-YB .....	<b>BS-13</b>
DIGI® S-T-U-V .....	<b>BS-14</b>

### BENCH SCALES WITH INDICATORS

DIGI® Bench Scale and Indicator Package <i>120/120 Plus</i> .....	<b>BS-15</b>
Ishida iPC Series <i>Portable Bench Scales</i> .....	<b>BS-16</b>
Versa-portion™ <i>RLP-S Series</i> .....	<b>BS-18</b>
Ishida IGX and IGB Series <i>Bench Scales</i> .....	<b>BS-19</b>



# Bench Scales

Bench Scales

## BenchMark™ SL, CW-80B, SL/HE Series Light-Capacity Bench Scales



### APPROVALS



Measurement Canada Approved  
Meets USDA Requirements



### STANDARD FEATURES

- 304 stainless steel construction
- LifeGuard™ base design isolates load cell from overloads and shock loads for added durability
- Specially designed adjustable support feet provide exceptional traction and won't scratch surfaces

#### SL Series additional features

- NTEP Certified aluminum load cell

#### CW-80B Series additional features

- NTEP Certified stainless steel load cell

#### SL/HE Series additional features

- NTEP Certified stainless steel, hermetically sealed load cell

### SPECIFICATIONS

#### LOAD CELL, NTEP - CERTIFIED:

SL Series: Aluminum and environmentally sealed  
CW-80B: Stainless steel and environmentally sealed IP67  
HE Series: Stainless steel, hermetically sealed IP69K

#### OUTPUT IMPEDANCE:

SL and CW-80B: 350 ohms  
HE: 1000 ohms

#### MAXIMUM OVERLOAD:

200%, except 150% for 30lb HE version

#### OVERLOAD PROTECTION:

Shock-absorbing spider

#### CABLE LENGTH:

10 ft (3m)

#### COMPENSATED TEMPERATURE RANGE:

14°F to 104°F (-10°C to 40°C)

#### APPROVALS:

SL and HE Series: NTEP Certified per H-44, Class III, 5000d, CC #95-072A2  
Measurement Canada approved, AM-5082  
CW-80B: NTEP Certified per H-44, Class III, 3000d, CC# 96-107 Measurement Canada approved, AM-5156

#### WARRANTY:

SL and CW-80B: Two-year limited warranty  
HE: Three-year limited warranty including water ingress

### DIMENSIONS

PART# (SL)	PART# (CW-80B)	PART # (SL/HE)	CAPACITY	PLATFORM SIZE (L X W)	L1/W1	H (SL & CW-80B)	H (HE)
18575*	N/A	N/A	2 lb (1 kg)	10 in x 10 in	10.25 in	3.15 in	3.58 in
18576	N/A	86942	5 lb (2.5 kg)	10 in x 10 in	10.25 in	3.15 in	3.58 in
N/A	35075	N/A	6 lb (3 kg)	10 in x 10 in	10.25 in	3.15 in	N/A
18577	35076	86943	10 lb (5 kg)	10 in x 10 in	10.25 in	3.15 in	3.58 in
N/A	35077	N/A	15 lb (7 kg)	10 in x 10 in	10.25 in	3.15 in	3.58 in
18578	N/A	86944	20 lb (10kg)	10 in x 10 in	10.25 in	3.15 in	3.58 in
18579	35078	86945	30 lb (15 kg)	10 in x 10 in	10.25 in	3.15 in	3.58 in
32914	35079	86946	30 lb (15 kg)	12 in x 12 in	12.25 in	3.25 in	3.63 in
32913	N/A	86947	50 lb (25 kg)	12 in x 12 in	12.25 in	3.25 in	3.63 in
N/A	35080	N/A	60 lb (30 kg)	12 in x 12 in	12.25 in	3.25 in	3.63 in
35198	N/A	86948	100 lb (50 kg)	12 in x 12 in	12.25 in	3.25 in	3.63 in

\*Non-NTEP

Note: 1"=25.4 mm

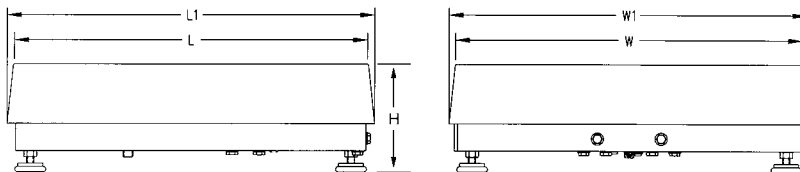

## BenchMark™ SL, CW-80B, SL/HE Series Light-Capacity Bench Scales

PART #	PLATFORM CAPACITY	DIMENSIONS	EST. SHIP WEIGHT	PRICE
<b>SL Series</b>				
18575*	2lb	10in x 10in x 3.15in	13lb	\$640.00
18576	5lb	10in x 10in x 3.15in	13lb	640.00
18577	10lb	10in x 10in x 3.15in	13lb	640.00
18578	20lb	10in x 10in x 3.15in	13lb	640.00
18579	30lb	10in x 10in x 3.15in	13lb	640.00
32914	30lb	12in x 12in x 3.25in	14lb	720.00
32913	50lb	12in x 12in x 3.25in	14lb	720.00
35198	100lb	12in x 12in x 3.25in	14lb	720.00
<b>CW-80B Series</b>				
35075	6lb	10in x 10in x 3.15in	13lb	730.00
35076	10lb	10in x 10in x 3.15in	13lb	730.00
35077	15lb	10in x 10in x 3.15in	13lb	730.00
35078	30lb	10in x 10in x 3.15in	13lb	730.00
35079	30lb	12in x 12in x 3.25in	14lb	840.00
35080	60lb	12in x 12in x 3.25in	14lb	840.00
<b>SL/HE Series</b>				
86942	5lb	10in x 10in x 3.58in	13lb	1,005.00
86943	10lb	10in x 10in x 3.58in	13lb	1,005.00
86944	20lb	10in x 10in x 3.58in	13lb	1,005.00
86945	30lb	10in x 10in x 3.58in	13lb	1,005.00
86946	30lb	12in x 12in x 3.63in	13lb	1,085.00
86947	50lb	12in x 12in x 3.63in	14lb	1,085.00
86948	100lb	12in x 12in x 3.63in	14lb	1,085.00

### OPTIONS/ACCESSORIES

53001	304 stainless steel clamshell for added load cell protection (for SL and CW-80B series)			75.00
112044	12in column for IQ plus® 355, IQ plus® 210, 320IS (without battery option), 320IS plus (without battery option), IQ plus® 390-DC, IQ plus® 590-DC, 420 plus®, CW-90 and CW-90X			135.00
112045**	18in column for IQ plus® 355 or IQ plus® 210, 320IS (without battery option), 320IS plus (without battery option), IQ plus® 390-DC, IQ plus® 590-DC, 420 plus®, CW-90 and CW-90X			180.00
64576	Attachment bracket for IQ plus® 355, IQ plus® 210 or 420 plus, 320IS (without battery option), 320IS plus (without battery option)			50.00
64577	Attachment bracket for IQ plus® 390-DC or IQ plus® 590-DC			50.00
22125	Additional operating manual			5.25

\* Non-NTEP

\*\* Not recommended for use with scale bases smaller than 12in x 12in

# Bench Scales

## CW-90B, CW-90XB

Light-Capacity Bench Scales

Bench Scales

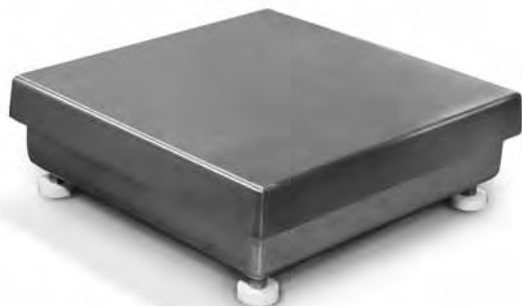

### STANDARD FEATURES

- 304 stainless steel construction
- Five point overload protection
- Specially designed adjustable support feet provide exceptional traction and will not scratch surfaces

#### CW-90B

- Aluminum environmentally sealed load cell

#### CW-90XB

- IP69K, stainless steel hermetically sealed load cell

### APPROVALS



Measurement  
Canada  
Approved

### SPECIFICATIONS

#### LOAD CELL, NTEP - CERTIFIED:

CW-90B: Aluminum and environmentally sealed  
CW-90XB: Stainless steel and hermetically sealed, IP69K

#### OUTPUT IMPEDANCE:

350 ohms

#### MAXIMUM OVERLOAD:

180% to 200% depending on capacity

#### OVERLOAD PROTECTION:

Five point, independently adjusted

#### CABLE LENGTH:

34 in or 10 ft

#### COMPENSATED TEMPERATURE

##### RANGE:

14°F to 104°F (-10°C to 40°C)

#### APPROVALS:

NTEP and Measurement Canada

#### WARRANTY:

CW-90B - two year

CW-90XB - three years including water ingress

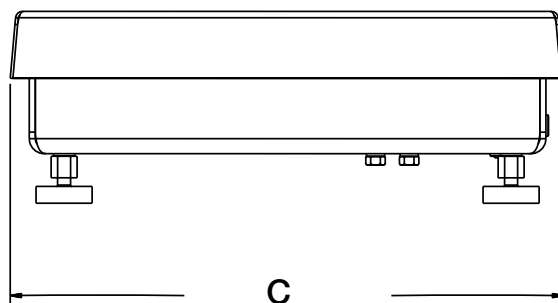
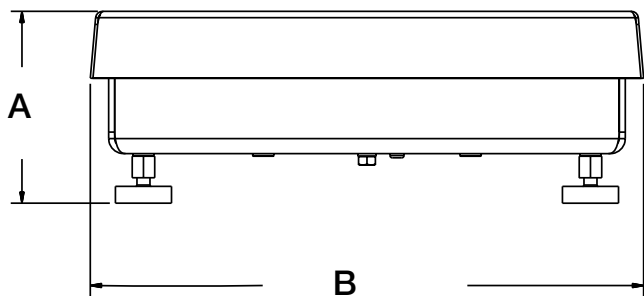

DIMENSIONS			
<b>CW-90B/CW-90XB (10 in)</b>			
<b>A</b>	4.25 in (107.95 mm)	<b>C</b>	10.37 in (263.40 mm)
<b>B</b>	10.37 in (263.40 mm)		
<b>CW-90B/CW-90XB (12 in)</b>			
<b>A</b>	4.25 in (107.95 mm)	<b>C</b>	12.37 in (314.20 mm)
<b>B</b>	12.37 in (314.20 mm)		

## CW-90B, CW-90XB

Light-Capacity Bench Scales

PART #	PLATFORM CAPACITY	DIMENSIONS	EST. SHIP WEIGHT	PRICE
<b>CW-90</b>				
<b>(10ft cable) (34 in cable)</b>				
112599	106137 .....5 lb	10 in x 10 in x 4.25 in	14 lb	\$640.00
112601	106138 .....10 lb	10 in x 10 in x 4.25 in	14 lb	640.00
112603	106139 .....25 lb	10 in x 10 in x 4.25 in	14 lb	640.00
112605	106140 .....25 lb	12 in x 12 in x 4.25 in	17 lb	720.00
112607	106141 .....50 lb	12 in x 12 in x 4.25 in	17 lb	720.00
112609	106142 .....100 lb	12 in x 12 in x 4.25 in	17 lb	720.00
<b>CW-90XB</b>				
<b>(10ft cable) (34 in cable)</b>				
112600	106143 .....5 lb	10 in x 10 in x 4.25 in	14 lb	1,005.00
112602	106144 .....10 lb	10 in x 10 in x 4.25 in	14 lb	1,005.00
112604	106145 .....25 lb	10 in x 10 in x 4.25 in	14 lb	1,005.00
112606	106146 .....25 lb	12 in x 12 in x 4.25 in	17 lb	1,085.00
112608	106147 .....50 lb	12 in x 12 in x 4.25 in	17 lb	1,085.00
112610	106148 .....100 lb	12 in x 12 in x 4.25 in	17 lb	1,085.00

Bench Scales

### OPTIONS/ACCESSORIES

112044.....	12 in column for IQ plus® 355, IQ plus® 210, 320IS (without battery option), 320IS plus (without battery option), IQ plus® 390-DC, IQ plus® 590-DC, 420 plus®, CW-90 and CW-90X .....	135.00
112045** .....	18 in column for IQ plus® 355 or IQ plus® 210, 320IS (without battery option), 320IS plus (without battery option), IQ plus® 390-DC, IQ plus® 590-DC, 420 plus®, CW-90 and CW-90X.....	180.00



### STANDARD FEATURES

- 304 stainless steel construction
- LifeGuard™ base design isolates load cell from overloads and shock loads for added durability
- Specially designed adjustable support feet provide exceptional traction and won't scratch surfaces

### APPROVALS



Measurement  
Canada  
Approved

Meets USDA  
Requirements



### SPECIFICATIONS

#### LOAD CELL, NTEP - CERTIFIED:

Mild steel and stainless steel: aluminum, environmentally sealed  
HE: Stainless steel, hermetically sealed, IP69

#### OUTPUT IMPEDANCE:

Mild steel and stainless steel: 350 ohms  
HE: 1000 ohms

#### MAXIMUM OVERLOAD:

150-200% depending on capacity

#### OVERLOAD PROTECTION:

Five point, independently adjusted

#### CABLE LENGTH:

10 ft (3m)

#### COMPENSATED TEMPERATURE RANGE:

14°F to 104°F (-10°C to 40°C)

#### APPROVALS:

NTEP Certified per H-44, Class III, 5000d, CC #95-072A2  
Measurement Canada approved, AM-5082

#### WARRANTY:

Mild steel and stainless steel:  
Two-year limited warranty  
HE: Three-year limited warranty including water ingress

## BenchMark™

Mild, Stainless Steel, HE Series

DIMENSIONS								
PART # (MILD)	PART # (STAINLESS)	PART # (HE)	CAPACITY	PLATFORM SIZE (L X W)	L1	W1	H (MILD & STAINLESS STEEL)	H (HE)
18580	N/A	N/A	30 (15kg)	12 in x 12 in	12.50in	12.50in	4.12in	N/A
18582	N/A	N/A	50 (25kg)	12 in x 12 in	12.50in	12.50in	4.12in	N/A
18584	N/A	N/A	100 (50kg)	12 in x 12 in	12.50in	12.50in	4.12in	N/A
18586	32918	86950	50 (25kg)	12 in x 18 in	12.50in	18.50in	MS 4.12in SST 3.62in	4in
18588	32919	86951	100 (50kg)	12 in x 18 in	12.50in	18.50in	MS 4.12in SST 3.62in	4in
18590	18591	86952	50 (25 kg)	18 in x 18 in	18.75in	18.75in	5.25in	5.25in
18592	18593	86953	100 (50kg)	18 in x 18 in	18.75in	18.75in	5.25in	5.25in
18594	18595	86954	150 (75kg)	18 in x 18 in	18.75in	18.75in	5.25in	5.25in
18596	18697	86955	200 (100kg)	18 in x 18 in	18.75in	18.75in	5.25in	5.25in
18598	18599	86956	250 (125kg)	18 in x 18 in	18.75in	18.75in	5.25in	5.5in
18600	18601	86957	300 (150kg)	18 in x 18 in	18.75in	18.75in	5.25in	5.5in
18602	18603	86958	500 (250kg)	18 in x 18 in	18.75in	18.75in	5.25in	5.5in
18604	18605	86959	1,000 (500kg)	18 in x 18 in	18.75in	18.75in	5.25in	5.5in
18606	18607	86960	50 (25kg)	18 in x 24 in	18.75in	24.75in	5.25in	5.25in
18608	18609	86961	100 (50kg)	18 in x 24 in	18.75in	24.75in	5.25in	5.25in
18610	18611	86962	150 (75kg)	18 in x 24 in	18.75in	24.75in	5.25in	5.25in
18612	18613	86963	200 (100kg)	18 in x 24 in	18.75in	24.75in	5.25in	5.25in
18614	18615	86964	250 (125kg)	18 in x 24 in	18.75in	24.75in	5.25in	5.5in
18616	18617	86965	300 (150kg)	18 in x 24 in	18.75in	24.75in	5.25in	5.5in
18618	18619	86966	500 (250kg)	18 in x 24 in	18.75in	24.75in	5.25in	5.5in
18620	18621	86967	1,000 (500kg)	18 in x 24 in	18.75in	24.75in	5.25in	5.5in
18622	18623	86968	100 (50kg)	24 in x 24 in	24.75in	24.75in	5.25in	5.25in
18624	18625	86969	150 (75kg)	24 in x 24 in	24.75in	24.75in	5.25in	5.25in
18626	18627	86970	200 (100kg)	24 in x 24 in	24.75in	24.75in	5.25in	5.25in
18628	18629	86971	250 (125kg)	24 in x 24 in	24.75in	24.75in	5.25in	5.5in
18630	18631	86972	300 (150kg)	24 in x 24 in	24.75in	24.75in	5.25in	5.5in
18632	18633	86973	500 (250kg)	24 in x 24 in	24.75in	24.75in	5.25in	5.5in
18634	18635	86974	1,000 (500kg)	24 in x 24 in	24.75in	24.75in	5.25in	5.5in

Note: 1"=25.4 mm

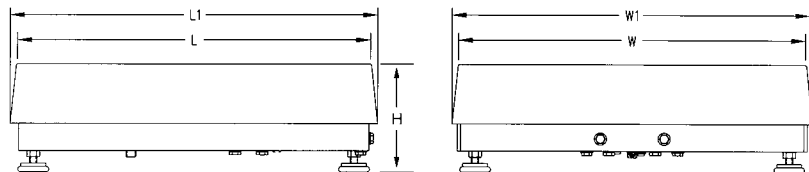

# Bench Scales

## BenchMark™

Mild, Stainless Steel, HE Series

Bench Scales

PART #	CAPACITY	PLATFORM DIMENSIONS	EST. SHIP WEIGHT	PRICE
<b>Mild Steel Series</b>				
18580	30lb	12 in x 12 in x 4.12 in	20lb	\$730.00
18582	50lb	12 in x 12 in x 4.12 in	20lb	730.00
18584	100lb	12 in x 12 in x 4.12 in	20lb	730.00
18586	50lb	12 in x 18 in x 4.12 in	37lb	810.00
18588	100lb	12 in x 18 in x 4.12 in	37lb	810.00
18590	50lb	18 in x 18 in x 5.25 in	68lb	990.00
18592	100lb	18 in x 18 in x 5.25 in	68lb	990.00
18594	150lb	18 in x 18 in x 5.25 in	68lb	990.00
18596	200lb	18 in x 18 in x 5.25 in	68lb	990.00
18598	250lb	18 in x 18 in x 5.25 in	68lb	990.00
18600	300lb	18 in x 18 in x 5.25 in	68lb	990.00
18602	500lb	18 in x 18 in x 5.25 in	68lb	990.00
18604	1,000lb	18 in x 18 in x 5.25 in	68lb	1,100.00
18606	50lb	18 in x 24 in x 5.25 in	78lb	1,100.00
18608	100lb	18 in x 24 in x 5.25 in	78lb	1,100.00
18610	150lb	18 in x 24 in x 5.25 in	78lb	1,100.00
18612	200lb	18 in x 24 in x 5.25 in	78lb	1,100.00
18614	250lb	18 in x 24 in x 5.25 in	78lb	1,100.00
18616	300lb	18 in x 24 in x 5.25 in	78lb	1,100.00
18618	500lb	18 in x 24 in x 5.25 in	78lb	1,100.00
18620	1,000lb	18 in x 24 in x 5.25 in	78lb	1,215.00
18622	100lb	24 in x 24 in x 5.25 in	78lb	1,215.00
18624	150lb	24 in x 24 in x 5.25 in	84lb	1,215.00
18626	200lb	24 in x 24 in x 5.25 in	84lb	1,215.00
18628	250lb	24 in x 24 in x 5.25 in	84lb	1,215.00
18630	300lb	24 in x 24 in x 5.25 in	84lb	1,215.00
18632	500lb	24 in x 24 in x 5.25 in	84lb	1,330.00
18634	1,000lb	24 in x 24 in x 5.25 in	84lb	1,330.00
<b>Stainless Steel Series</b>				
32918	50lb	12 in x 18 in x 3.62 in	37lb	900.00
32919	100lb	12 in x 18 in x 3.62 in	37lb	900.00
18591	50lb	18 in x 18 in x 5.25 in	68lb	1,245.00
18593	100lb	18 in x 18 in x 5.25 in	68lb	1,245.00
18595	150lb	18 in x 18 in x 5.25 in	68lb	1,245.00
18597	200lb	18 in x 18 in x 5.25 in	68lb	1,245.00
18599	250lb	18 in x 18 in x 5.25 in	68lb	1,245.00
18601	300lb	18 in x 18 in x 5.25 in	68lb	1,245.00
18603	500lb	18 in x 18 in x 5.25 in	68lb	1,395.00
18605	1,000lb	18 in x 18 in x 5.25 in	68lb	1,395.00
18607	50lb	18 in x 24 in x 5.25 in	78lb	1,480.00
18609	100lb	18 in x 24 in x 5.25 in	78lb	1,480.00
18611	150lb	18 in x 24 in x 5.25 in	78lb	1,480.00
18613	200lb	18 in x 24 in x 5.25 in	78lb	1,480.00
18615	250lb	18 in x 24 in x 5.25 in	78lb	1,480.00
18617	300lb	18 in x 24 in x 5.25 in	78lb	1,480.00
18619	500lb	18 in x 24 in x 5.25 in	78lb	1,480.00
18621	1,000lb	18 in x 24 in x 5.25 in	78lb	1,765.00
18623	100lb	24 in x 24 in x 5.25 in	84lb	1,765.00
18625	150lb	24 in x 24 in x 5.25 in	84lb	1,825.00
18627	200lb	24 in x 24 in x 5.25 in	84lb	1,825.00
18629	250lb	24 in x 24 in x 5.25 in	84lb	1,825.00
18631	300lb	24 in x 24 in x 5.25 in	84lb	1,825.00
18633	500lb	24 in x 24 in x 5.25 in	84lb	1,905.00
18635	1,000lb	24 in x 24 in x 5.25 in	84lb	1,905.00

## BenchMark™

Mild, Stainless Steel, HE Series

PART #	CAPACITY	PLATFORM DIMENSIONS	EST. SHIP WEIGHT	PRICE
<b>HE Series</b>				
86950	50lb	12 in x 18 in x 4 in	37 lb	\$1,270.00
86951	100lb	12 in x 18 in x 4 in	37 lb	1,270.00
86952	50lb	18 in x 18 in x 5.25 in	68 lb	1,615.00
86953	100lb	18 in x 18 in x 5.25 in	68 lb	1,615.00
86954	150lb	18 in x 18 in x 5.25 in	68 lb	1,615.00
86955	200lb	18 in x 18 in x 5.25 in	68 lb	1,615.00
86956	250lb	18 in x 18 in x 5.5 in	68 lb	1,770.00
86957	300lb	18 in x 18 in x 5.5 in	68 lb	1,770.00
86958	500lb	18 in x 18 in x 5.5 in	68 lb	1,920.00
86959	1,000lb	18 in x 18 in x 5.5 in	68 lb	1,920.00
86960	50lb	18 in x 24 in x 5.25 in	78 lb	1,850.00
86961	100lb	18 in x 24 in x 5.25 in	78 lb	1,850.00
86962	150lb	18 in x 24 in x 5.25 in	78 lb	1,850.00
86963	200lb	18 in x 24 in x 5.25 in	78 lb	1,850.00
86964	250lb	18 in x 24 in x 5.5 in	78 lb	2,010.00
86965	300lb	18 in x 24 in x 5.5 in	78 lb	2,010.00
86966	500lb	18 in x 24 in x 5.5 in	78 lb	2,290.00
86967	1,000lb	18 in x 24 in x 5.5 in	78 lb	2,290.00
86968	100lb	24 in x 24 in x 5.25 in	84 lb	2,190.00
86969	150lb	24 in x 24 in x 5.25 in	84 lb	2,190.00
86970	200lb	24 in x 24 in x 5.25 in	84 lb	2,190.00
86971	250lb	24 in x 24 in x 5.5 in	84 lb	2,350.00
86972	300lb	24 in x 24 in x 5.5 in	84 lb	2,350.00
86973	500lb	24 in x 24 in x 5.5 in	84 lb	2,430.00
86974	1,000lb	24 in x 24 in x 5.5 in	84 lb	2,430.00

### OPTIONS/ACCESSORIES

53001**	304 stainless steel clamshell for added load cell protection (12 in x 12 in, 12 in x 18 in) (for mild and stainless steel)			75.00
41292**	304 stainless steel clamshell for added load cell protection (18 in x 18 in, 18 in x 24 in and 24 in x 24 in), except not 1,000lb capacity (for mild and stainless steel)			90.00
18805**	304 stainless steel clamshell for added load cell protection (18 in x 18 in 18 in x 24 in and 24 in x 24 in), 1,000lb capacity only			100.00
112044	12 in column for IQ plus® 355 or IQ plus® 210, 320IS (without battery option), 320IS Plus (without battery option), 390-DC or IQ plus® 590-DC, 420 plus®, CW-90 and CW-90X			135.00
112045*	18 in column for IQ plus® 355 or IQ plus® 210, 320IS (without battery option), 320IS Plus (without battery option) 390-DC or IQ plus® 590-DC, 420 plus®, CW-90 and CW-90X			180.00
64576	Attachment bracket for IQ plus® 355 or IQ plus® 210, 420 plus, 320IS (without battery option), 320IS Plus (without battery option)			50.00
64577	Attachment bracket for IQ plus® 390-DC or IQ plus® 590-DC			50.00
22125	Additional operating manual			5.25

\* Not recommended for use with scale bases smaller than 12 in x 12 in

\*\* Not for use with HE Series

# Bench Scales

## BenchMark™ LP

Low Profile Bench Scales

Bench Scales



### STANDARD FEATURES

- Mild steel base construction
- 304 stainless steel cover
- ABS junction box
- Four planar beam load cells
- Adjustable leveling feet
- 20ft of EL147 load cell cable
- Holes in lower frame for mounting scale without adjustable leveling feet



Ideal for Aviation Weighing. A complete system can be sold with the Tracer® AV. Reference Instrumentation/Process Control for specifications

### APPROVALS



Measurement  
Canada  
Approved

### SPECIFICATIONS

#### LOAD CELL, RATED OUTPUT:

1.0mV/V +/- 10%

#### END LOAD CAPACITY:

60% of full scale capacity

#### CABLE LENGTH:

20ft (6.1m) for connecting j-box to indicator

#### APPROVALS:

NTEP Certified except 1000lb capacity,  
Measurement Canada Approved AM-5660,  
except 500kg capacity

#### WARRANTY:

Two-year limited warranty

PART #	CAPACITY	PLATFORM DIMENSIONS	EST. SHIP WEIGHT	PRICE
97662.....	100lb (50kg).....	18 in x 18 in x 2.54 in (2.00in*).....	75 lb .....	\$1,065.00
97663.....	250lb (125kg).....	18 in x 18 in x 3.06 in (2.18in*).....	85 lb .....	1,090.00
97664.....	500lb (250kg).....	18 in x 18 in x 3.06 in (2.26in*).....	85 lb .....	1,115.00
97665.....	100lb (50kg).....	24 in x 24 in x 2.54 in (2.00in*).....	85 lb .....	1,275.00
97666.....	250lb (125kg).....	24 in x 24 in x 3.00 in (2.18in*).....	100 lb .....	1,300.00
97667.....	500lb (250kg).....	24 in x 24 in x 3.06 in (2.26in*).....	100 lb .....	1,325.00
97668.....	500lb (250kg).....	30 in x 30 in x 3.06 in (2.26in*).....	135 lb .....	1,525.00
97669** .....	1,000lb (500kg).....	30 in x 30 in x 3.38 in (2.58in*).....	135 lb .....	1,575.00
97670.....	500lb (250kg).....	36 in x 36 in x 3.06 in (2.26in*).....	175 lb .....	2,000.00
97671** .....	1,000lb (500kg).....	36 in x 36 in x 3.38 in(2.58in*).....	175 lb .....	2,050.00

\*Height without adjustable leveling feet

\*\* Non-Ntep and not measurement Canada Approved

## BenchMark™ HD

Heavy Duty Bench Scales



### STANDARD FEATURES

- Mild steel base construction
- 304 stainless steel cover
- Polyurethane rubber leveling feet with stainless steel stem
- Adjustable height 8.75 in to 9.75 in



Ideal for Aviation Weighing. A complete system can be sold with the Tracer® AV. Reference Instrumentation/Process Control for specifications

### APPROVALS



Measurement  
Canada  
Approved



### SPECIFICATIONS

#### LOAD CELL, NTEP - CERTIFIED:

Aluminum, environmentally sealed

#### OUTPUT IMPEDANCE:

350 ohms

#### MAXIMUM OVERLOAD:

200%

#### OVERLOAD PROTECTION:

Five-point, independently adjusted

#### CABLE LENGTH:

10 ft (3m)

#### COMPENSATED TEMPERATURE RANGE:

14°F to 104°F/-10°C to 40°C

#### APPROVALS:

NTEP Certified 06-010A1, 5,000d  
Measurement Canada Approved AM-5625

#### WARRANTY:

Two-year limited warranty

PART #	CAPACITY	PLATFORM DIMENSIONS	EST. SHIP WEIGHT	PRICE
93414.....	250 lb (125 kg).....	30 in x 30 in x 8.75 in.....	300 lb.....	\$1,675.00
93415.....	500 lb (225 kg).....	30 in x 30 in x 8.75 in.....	300 lb.....	1,675.00
93416.....	250 lb (125 kg).....	36 in x 36 in x 8.75 in.....	330 lb.....	2,035.00
93417.....	500 lb (225 kg).....	36 in x 36 in x 8.75 in.....	330 lb.....	2,035.00

Consult factory for modifications for airport baggage scales.

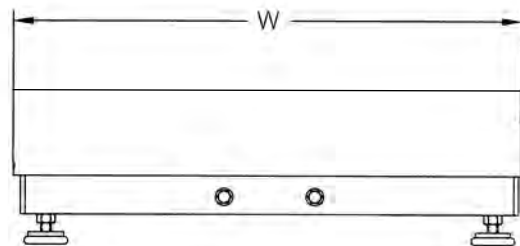
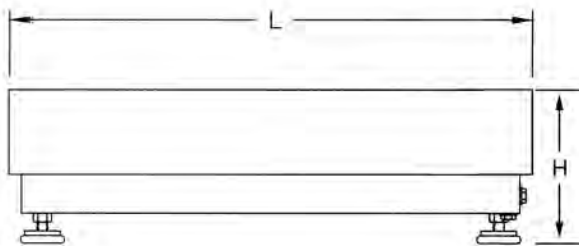

# Bench Scales

## BenchMark™ HDP

## Portable Heavy Duty Bench Scales

Bench Scales

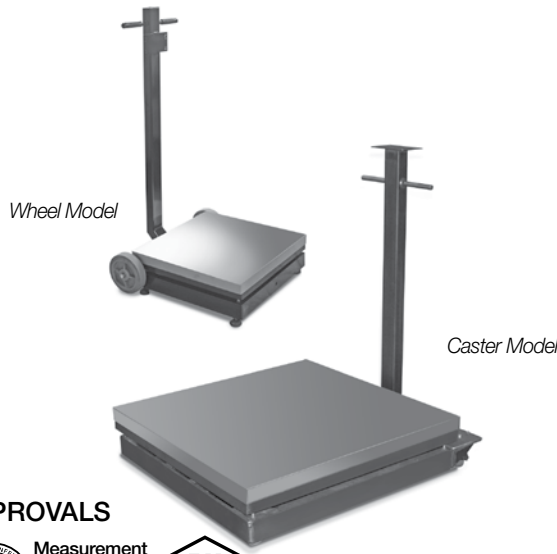

### STANDARD FEATURES

- Mild steel base construction
- 304 stainless steel cover
- Indicator stand for mounting IQ plus 355, IQ plus 390-DC, IQ plus 590-DC

#### Wheel Model

- Polyurethane rubber leveling feet with stainless steel stems
- 8 in diameter preformed rubber wheels with ball bearings

#### Caster Model

- 3 1/2 in diameter preformed rubber casters, two fixed, two swivel with lock



Ideal for Aviation Weighing. A complete system can be sold with the Tracer® AV. Reference Instrumentation/Process Control for specifications

### APPROVALS



Measurement  
Canada  
Approved



### SPECIFICATIONS

#### LOAD CELL, NTEP - CERTIFIED:

Aluminum, environmentally sealed

#### OUTPUT IMPEDANCE:

350 ohms

#### MAXIMUM OVERLOAD:

200%

#### OVERLOAD PROTECTION:

Five-point, independently adjusted

#### CABLE LENGTH:

10 ft (3m)

#### COMPENSATED TEMPERATURE

#### RANGE:

14°F to 104°F/-10°C to 40°C

#### APPROVALS:

NTEP Certified 06-010A1, 5000 div

Measurement Canada Approved AM-5625

#### WARRANTY:

Two-year limited warranty

PART #	CAPACITY	PLATFORM DIMENSIONS	EST. SHIP WEIGHT	PRICE
<b>Wheel Model</b>				
97072.....	250 lb (125 kg).....	24 in x 24 in x 8.75 in .....	275 lb .....	\$1,675.00
97073.....	500 lb (225 kg).....	24 in x 24 in x 8.75 in .....	275 lb .....	1,675.00
<b>Caster Model</b>				
97074.....	250 lb (125 kg).....	24 in x 24 in x 9.31 in .....	290 lb .....	1,675.00
97075.....	500 lb (225 kg).....	24 in x 24 in x 9.31 in .....	290 lb .....	1,675.00

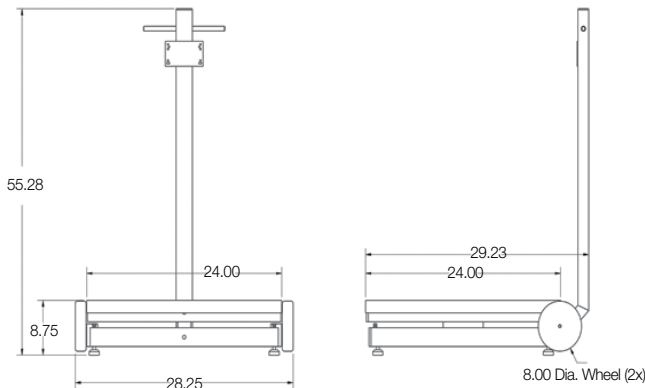

Wheel Model

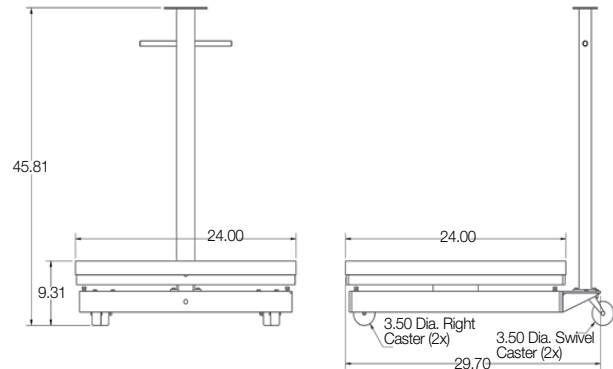

Caster Model

## DIGI® S-YA/S-YB



### STANDARD FEATURES

- Rust-proof coated carbon steel base
- Stainless steel platter
- Maintains 0.03% accuracy through full range
- Large 3 in (76.2 mm) adjustable leveling feet
- Aluminum load cell

### SPECIFICATIONS

**LOAD CELL MATERIAL:**

Aluminum, butyl rubber coated

**LOAD CELL TYPE:**

Single point strain gauge

**RECOMMENDED EXC. VOLTAGE:**

5-12VDC

**MAX EXC. VOLTAGE:**

S-YA: 12VDC, AC  
S-YB: 20VDC, AC

**OUTPUT IMPEDANCE:**

1000 ±10Ω (S-YA)  
350 ±10Ω (S-YB)

**INSULATION RESISTANCE:**

500MΩ

**LOAD CELL CABLE LENGTH:**

8 ft (2.4 m) with 14 pin connector

**TEMPERATURE RANGE:**

14°F to 104°F (10°C to 40°C)

**WARRANTY:**

Two-year limited warranty

**LOAD CELL COLOR CODE:**

Red +Excitation  
White - Excitation  
Green +Signal  
Yellow - Signal  
Blue +Sense  
Orange - Sense  
Bare Shield

PART#	MODEL	CAPACITY	PLATFORM DIMENSION	EST. SHIP WEIGHT	PRICE
74151.....	S-YA .....	60lb (30kg) .....	15 in x 15 in .....	25lb (12kg).....	\$615.00
74152.....	S-YA .....	150lb (60kg) .....	15 in x 15 in .....	25lb (12kg).....	615.00
74153.....	S-YA .....	300lb (150kg) .....	15 in x 15 in .....	25lb (12kg).....	615.00
74154.....	S-YB.....	150lb (60kg).....	19 in x 19 in .....	48lb (22kg).....	615.00
74155.....	S-YB.....	300lb (150kg) .....	19 in x 19 in .....	48lb (22kg).....	615.00
74156.....	S-YB.....	500lb (300kg) .....	19 in x 19 in .....	48lb (22kg).....	615.00

# Bench Scales

## DIGI® S-T-U-V

Bench Scales



### STANDARD FEATURES

- IP66-rated
- Platform support in each corner
- Shock resistant load cells
- Rated to 300% overload

### APPROVALS



Measurement  
Canada  
Approved

### SPECIFICATIONS

#### RECOMMENDED EXC. VOLTAGE:

5-12VDC

#### MAX EXC. VOLTAGE:

20VAC/DC

#### OUTPUT IMPEDANCE:

350 ±10Ω

#### INSULATION RESISTANCE:

500MΩ or more

#### RATED OUTPUT:

0.83mV/V ±7.5%

#### RATED INPUT:

1mV/V ±7.5%

#### LOAD CELL CABLE LENGTH:

S-S/S-T: 9ft (3m) with 14 pin connector

S-U: 18ft (5.5m) with 14 pin connector

S-V: 28ft (8.5m) with 14 pin connector

#### APPROVALS:

NTEP Certified per H-44, Class III, 5000d,  
CC#02-111, Measurement Canada Approved  
AM-5393

#### TEMPERATURE RANGE:

14°F to 104°F (-10°C to 40°C)

#### WARRANTY:

Two-year limited warranty

PART#	MODEL	CAPACITY	DIMENSIONS	EST. SHIP WEIGHT	PRICE
<b>Carbon Steel Platform – Stainless Steel Platter</b>					
73248†	S-SL	60lb (30kg)	13in x 17in x 3.5in	30lb (14kg)	\$715.00
73246	S-SL	150lb (60kg)	13in x 17in x 3.5in	30lb (14kg)	715.00
73247	S-SL	300lb (150kg)	13in x 17in x 3.5in	30lb (14kg)	715.00
73250	S-TL	150lb (60kg)	17in x 21in x 4.5in	50lb (23kg)	920.00
73251	S-TL	300lb (150kg)	17in x 21in x 4.5in	50lb (23kg)	920.00
73252†	S-TL	500lb (300kg)	17in x 21in x 4.5in	50lb (23kg)	920.00
74508	S-UL	150lb (60kg)	24in x 28in x 5in	90lb (41kg)	1,130.00
73256	S-UL	300lb (150kg)	24in x 28in x 5in	90lb (41kg)	1,130.00
73257	S-UL	500lb (300kg)	24in x 28in x 5in	90lb (41kg)	1,130.00
76511*	S-VL	1,500lb (600kg)	24in x 28in x 6in	130lb (59kg)	1,130.00

\* Non NTEP

† Measurement Canada Approved

## DIGI® Bench Scale and Indicator Package

120/120 Plus



### STANDARD FEATURES

- Large 0.8in (20.3mm) six-digit red LED or LCD display
- 115 VAC
- EPD and printer port for connecting to a PC or printer
- Programmable print output strings
- Available in 150lb/60kg, 300lb/150kg, 500lb/300kg capacities
- Selectable unit of measure lb/kg/g/oz
- Load cell quick disconnect
- Carbon steel platform, stainless steel platter (STL)

### APPROVALS



### SPECIFICATIONS

#### POWER:

Line voltages: 115  
 Frequency: 50 or 60Hz  
 120 Plus Power consumption:  
 (estimated battery life)  
 60 hours with 1 x 350 Ω  
 40 hours with 4 x 350 Ω  
 Charge time 8 hours

#### SERIAL OUTPUT:

EDP port: Full duplex RS-232  
 Printer port:  
 Output-only RS-232 or active 20mA current loop  
 Both ports:  
 9600, 4800, 2400, 1200, 600, 300 bps; 7 or 8  
 data bits; even, odd or no parity

#### DISPLAY:

0.8in (20mm), 6-digit Super Red Light Emitting Diode (LED) display, 7-segment, digits  
 \*0.8in (20mm) 6-digit LCD with backlight  
 7-segment digits

#### STATUS ANNUNCIATORS:

Designators for: center of zero, stand still, gross, net center of zero, standstill, lb, kg, oz, g  
 \*Battery, setpoint 1 and 2, HI-OK-LO, Hold

#### KEYBOARD:

5-key flat membrane panel, tactile feel  
 \*zero, tare, present tare, hold, BMI, units, numeric 0-9, clear, enter

#### OPERATING TEMPERATURE:

-10°C to 40°C/14°F to 104°F (legal)  
 -10°C to 50°C/14°F to 122°F (industrial)

#### RATING/MATERIAL:

Enclosure: heavy gauge ABS

#### SCALE APPROVALS:

NTEP Certified per H-44, Class III, 5000d, Measurement Canada approved, AM-5393

#### WARRANTY:

One-year limited warranty

\* Specifications apply to the 120 Plus

PART #	CAPACITY	PLATFORM DIMENSIONS	EST. SHIP WEIGHT	PRICE
<b>120</b>				
83303.....	150lb/60kg x 0.05lb/0.02kg .....	17 in x 21 in x 4.5 in.....	57 lb .....	\$940.00
83304.....	300lb/150kg x 0.1lb/0.05kg .....	17 in x 21 in x 4.5 in.....	57 lb .....	940.00
83305.....	500lb/300kg x 0.1lb/0.1kg .....	17 in x 21 in x 4.5 in.....	57 lb .....	940.00
<b>120 Plus</b>				
106908.....	150lb/60kg x 0.05lb/0.02kg .....	17 in x 21 in x 4.5 in.....	57 lb .....	1,090.00
106909.....	300lb/150kg x 0.1lb/0.05kg .....	17 in x 21 in x 4.5 in.....	57 lb .....	1,090.00
106910.....	500lb/300kg x 0.1lb/0.1kg .....	17 in x 21 in x 4.5 in.....	57 lb .....	1,090.00

### OPTIONS/ACCESSORIES

73381..... 4in (100mm) castors (four swivels, two with brakes) ..... 250.00

<b>A</b> 21 in	<b>D</b> 3.94 in
<b>B</b> 24.6 in	<b>E</b> 23.9 in
<b>C</b> 17 in	<b>F</b> 32.6 in

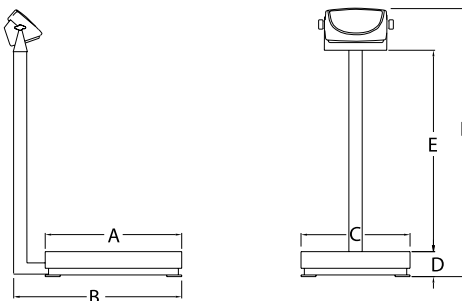

Bench Scales with Indicators

## Ishida iPC Series

Portable Bench Scales



iPC with dual display



### APPROVALS



### SPECIFICATIONS

#### DISPLAY:

Six digits (7-segment), LCD  
Character height: 1 in (25.4 mm)

#### KEYBOARD:

Zero, tare, on/off, unit (lb/kg)  
NOTE: oz version only displays weight in oz

#### POWER:

Two dry cell "D" type batteries\* (up to 500 hours)  
or AC adapter  
Auto power-off function (can be set to 60 min.,  
20 min., or off)

#### OPERATIONAL TEMPERATURE:

23°F to 104°F (-5°C to 40°C)

#### DIVISIONS (AUTO RANGING):

100 oz: 0.05 oz from 0–50 oz, 0.1 oz  
from 50–100 oz  
6 lb (3 kg): 0.002 lb (0.001 kg)  
from 0–3 lb (0–1.5 kg), 0.005 lb (0.002 kg) from  
3–6 lb (1.5–3 kg)  
15 lb (6 kg): 0.005 lb (0.002 kg)  
from 0–6 lb (0–3 kg), 0.01 lb (0.005 kg)  
from 6–15 lb (3–6 kg)  
30 lb (15 kg): 0.01 lb (0.005 kg)  
from 0–15 lb (0–7.5 kg), 0.02 lb (0.01 kg)  
from 15–30 lb (7.5–15 kg)  
60 lb (30 kg): 0.02 lb (0.01 kg)  
from 0–30 lb (0–15 kg), 0.05 lb (0.02 kg)  
from 30–60 lb (15–30 kg)

#### APPROVALS:

NTEP Certified CC# 02-139, UL listed

#### PLATTER SIZE:

100 oz: (3 kg) 9.1 in x 7.8 in (231 mm x 198.1 mm)  
6 lb (3 kg): 9.1 in x 7.8 in (231 mm x 198.1 mm)  
15 lb (6 kg): 9.1 in x 7.8 in (231 mm x 198.1 mm)  
30 lb (15 kg): 11 in x 11.5 in (279.4 mm x  
292.1 mm)  
60 lb (30 kg): 11 in x 11.5 in (279.4 mm x  
292.1 mm)

#### WARRANTY:

One-year limited warranty

Bench Scales  
with Indicators

PART #	CAPACITY	PLATFORM DIMENSIONS	EST. SHIP WEIGHT
<b>Single display</b>			
75466.....	100 oz .....	9.1 in x 7.8 in.....	6 lb
<b>Single display, Multi-ranging</b>			
75454.....	6 lb (3 kg).....	9.1 in x 7.8 in.....	6 lb
75455.....	15 lb (6 kg).....	9.1 in x 7.8 in.....	6 lb
75457.....	30 lb (15 kg).....	11 in x 11.5 in.....	8 lb
75458.....	60 lb (30 kg).....	11 in x 11.5 in.....	8 lb
<b>Dual display</b>			
75468.....	100 oz .....	9.1 in x 7.8 in.....	6 lb
<b>Dual display, multi-ranging</b>			
75460.....	6 lb (3 kg).....	9.1 in x 7.8 in.....	6 lb
75461.....	15 lb (6 kg).....	9.1 in x 7.8 in.....	6 lb
75462.....	30 lb (15 kg).....	11 in x 11.5 in.....	8 lb
75464.....	60 lb (30 kg).....	11 in x 11.5 in.....	8 lb

### OPTIONS/ACCESSORIES

- 75470..... Stainless steel platter cover (100 oz, 6 lb, and 15 lb capacity)
- 75739..... Stainless steel platter cover (30 lb and 60 lb capacity)
- 75473..... AC adapter
- 75889..... Additional operating manual

DIMENSIONS			
<b>A</b>	9.3 in (236.2 mm)	<b>F</b>	11.3 in (287 mm)
<b>B</b>	9.1 in (231.1 mm)	<b>G</b>	11 in (279.4 mm)
<b>C</b>	7.8 in (198.1 mm)	<b>H</b>	11.5 in (292.1 mm)
<b>D</b>	11.1 in (281.9 mm)	<b>I</b>	14.3 in (363.2 mm)
<b>E</b>	3.9 in (99.1 mm)	<b>J</b>	4 in (101.6 mm)

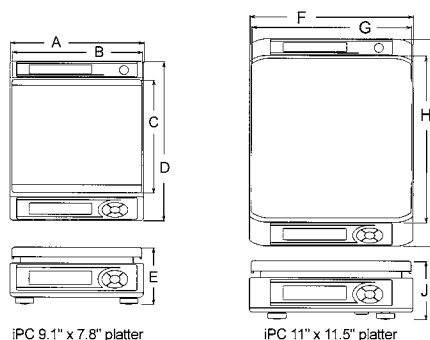

## Ishida iPC Series

Portable Bench Scales

PART #	CAPACITY	PLATFORM DIMENSIONS	EST. SHIP WEIGHT	PRICE
<b>Single display</b>				
75466.....	100 oz .....	9.1 in x 7.8 in .....	.6 lb .....	\$230.00
<b>Single display, multi-ranging</b>				
75454.....	6 lb (3 kg).....	9.1 in x 7.8 in .....	.6 lb .....	230.00
75455.....	15 lb (6 kg).....	9.1 in x 7.8 in .....	.6 lb .....	230.00
75457.....	30 lb (15 kg).....	11 in x 11.5 in .....	.8 lb .....	230.00
75458.....	60 lb (30 kg).....	11 in x 11.5 in .....	.8 lb .....	230.00
<b>Dual Display</b>				
75468.....	100 oz .....	9.1 in x 7.8 in .....	.6 lb .....	250.00
<b>Dual display, multi-ranging</b>				
75460.....	6 lb (3 kg).....	9.1 in x 7.8 in .....	.6 lb .....	250.00
75461.....	15 lb (6 kg).....	9.1 in x 7.8 in .....	.6 lb .....	250.00
75462.....	30 lb (15 kg).....	11 in x 11.5 in .....	.8 lb .....	250.00
75464.....	60 lb (30 kg).....	11 in x 11.5 in .....	.8 lb .....	250.00

### OPTIONS/ACCESSORIES

75470.....	Stainless steel platter cover (100 oz, 6 lb, and 15 lb capacity).....			20.00
75739.....	Stainless steel platter cover (30 lb and 60 lb capacity).....			20.00
75473.....	AC adapter .....			25.00
75889.....	Additional operating manual.....			25.00

Bench Scales with Indicators

# Bench Scales

## **NEW** Versa-portion™

Compact Scale



### APPROVALS



Measurement  
Canada  
Approved

### STANDARD FEATURES

- Compact design and easy to use
- Water and dust resistant and IP68
- Stainless steel housing with an ABS plastic base
- Removable weigh pan—quick and easy cleaning
- LED Display
- AC adapter included
- Legal-for-Trade
- Meets HACCP requirements

#### Optional Features:

- Rechargeable battery
- Custom pans or fixtures:  
Ice cream holder  
French fry holder  
Sandwich pan  
Diaper pan

### SPECIFICATIONS

#### DISPLAY:

LED, 6 digits

#### CAPACITY:

Pound	Gram	Ounce
6.0 x 0.002 lb / 3000 x 1g	/ 60.0 x 0.02 oz	
15.0 x 0.005 lb / 6000 x 2g	/ 150.0 x 0.05 oz	
30.0 x 0.01 lb / 15000 x 5g	/ 300.0 x 0.1 oz	
60.0 x 0.02 lb / 30000 x 10g	/ 600.0 x 0.2 oz	

#### DISPLAY INDICATORS:

Ounces, grams, pounds, NET, center of zero, battery usage

#### KEYBOARD:

Rezero, Tare, On/Off, Unit

#### RESOLUTION:

Display resolution 1/3,000  
Internal resolution 1/90,000

#### PLATTER SIZE:

9.3 x 7.8 in  
(237.2 x 198.0mm)

#### OPERATING HUMIDITY:

15 ~ 85% RH

#### OPERATING TEMPERATURE:

14°F to 104°F (-10°C to +40°C)

#### POWER CONSUMPTION:

18W when using DC power  
3W when using rechargeable battery  
(battery life: 60 hours of continuous usage)

#### POWER SOURCE:

DC 12V/1.5A, DC 6V5Ah  
Optional rechargeable battery

#### CALIBRATION:

Grams

#### DIMENSIONS:

9.9 x 11.4 x 5.3 in  
(251.6 x 289.7 x 134.6 mm)

#### APPROXIMATE WEIGHT:

13.9 lb / 6.3kg

#### PACKAGE SIZE:

377 x 337 x 245 mm  
(14.8 x 13.3 x 9.6 in)

#### APPROVALS:

NTEP CC 10-068 Class III  
Measurement Canada AM-5794

#### WARRANTY:

One-year limited warranty

Bench Scales  
with Indicators

PART #	DESCRIPTION	CAPACITY	EST. SHIP WEIGHT	PRICE
115125.....	RLP-6S .....	6.00lb x 0.002 lb .....	15lb/6.3kg .....	\$395.00
115128.....	RLP-15S .....	15.00lb x 0.005 lb .....	15lb/6.3kg .....	395.00
115129.....	RLP-30S .....	30.00lb x 0.01 lb .....	15lb/6.3kg .....	395.00
115130.....	RLP-60S .....	60.00lb x 0.02 lb .....	15lb/6.3kg .....	395.00

### OPTIONS/ACCESSORIES

108516.....	Rechargeable battery .....	35.00
108518.....	AC adapter 110-230VAC .....	45.00
115519.....	Operator guide .....	10.00
Consult.....	Ice cream holder .....	Consult
Consult.....	French fry holder .....	Consult
Consult.....	Sandwich pan .....	Consult
Consult.....	Diaper pan .....	Consult

## Ishida IGX and IGB Series

Bench Scales



### STANDARD FEATURES

- Ability to toggle between lb and kg
- Stainless steel cover with die cast base
- Checkweighing function
- Configurable display resolution: 1/3000, 1/6000, 1/7500 (NOTE: Legal-for-trade setting is 1/3000)
- 10 PLUs for storing tare, upper limit, lower limit

#### IGX:

- Display, VFD
- Power, 120VAC
- Internal buzzer

#### IGB:

- Display, LCD
- Power, (2) D-size batteries\* or optional AC adapter
- Selectable automatic power-off function

\*Batteries not included

### APPROVALS



### SPECIFICATIONS

#### CAPACITY:

IGX 150lb/60kg x .05lb/0.02 kg  
 IGX 300lb/150kg x .1 lb/0.05 kg  
 IGB 150lb/60kg x 0.05 lb/0.02 kg  
 IGB 300lb/150kg x 0.1 lb/0.05 kg

#### ACCURACY:

Configurable 1/3000\*\*, 1/6000, 1/7500  
 \*\*Legal-for-trade setting

#### DISPLAY:

IGX: Vacuum Fluorescent Display (VFD), 25mm  
 IGB: Liquid Crystal Display (LCD), 29mm

#### FOOT DIMENSIONS:

2 1/1 in dia, 3/4 in height, 2 1/4 in height including stem

#### DISPLAY ITEMS:

Weight: 5 digits  
 Center of zero  
 Tare  
 Checkweighing: Over "H", Under "L"

#### ELECTRICAL POWER:

IGX: 120V  
 IGB: "D" size batteries or optional AC adapter (batteries not included) 500 hour battery life

#### OPERATING TEMPERATURE:

23°F to 109°F (-5°C to 40°C)

#### APPROVALS:

NTEP Certified per H-44, Class III, 3000d

#### WARRANTY:

One-year limited warranty

PART #	DESCRIPTION	CAPACITY	PLATFORM DIMENSIONS	EST. SHIP WEIGHT	PRICE
84989.....	IGX .....	150lb/60kg x .05lb/0.02 kg .....	15.75 in x 21.65 in x 5.43 in .....	43 lb .....	\$695.00
84990.....	IGX .....	300lb/150kg x 0.1 lb/0.05 kg .....	15.75 in x 21.65 in x 5.43 in .....	43 lb .....	695.00
84991.....	IGB .....	150lb/60kg x 0.05 lb/0.02 kg.....	15.75 in x 21.65 in x 5.43 in .....	41 lb .....	595.00
84992.....	IGB .....	300lb/150kg x 0.1 lb/0.05 kg.....	15.75 in x 21.62 in x 5.43 in .....	41 lb .....	595.00

### OPTIONS/ACCESSORIES

75473.....	AC adapter (IGB only) .....	25.00
86545.....	Additional operating manual (IGX/IGB) .....	25.00

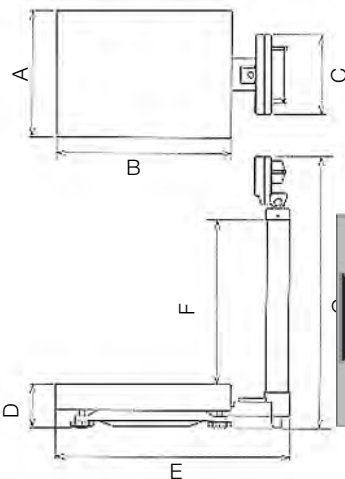

DIMENSIONS			
<b>A</b>	15.75 in (400mm)	<b>B</b>	21.65 in (550mm)
<b>C</b>	9.84 in (250mm)	<b>D</b>	5.43 in (138mm)
<b>E</b>	29.06 in (738mm)	<b>F</b>	22.00 in (560mm)
<b>G</b>	33.70 in (856mm)		



Bench Scales with Indicators

